

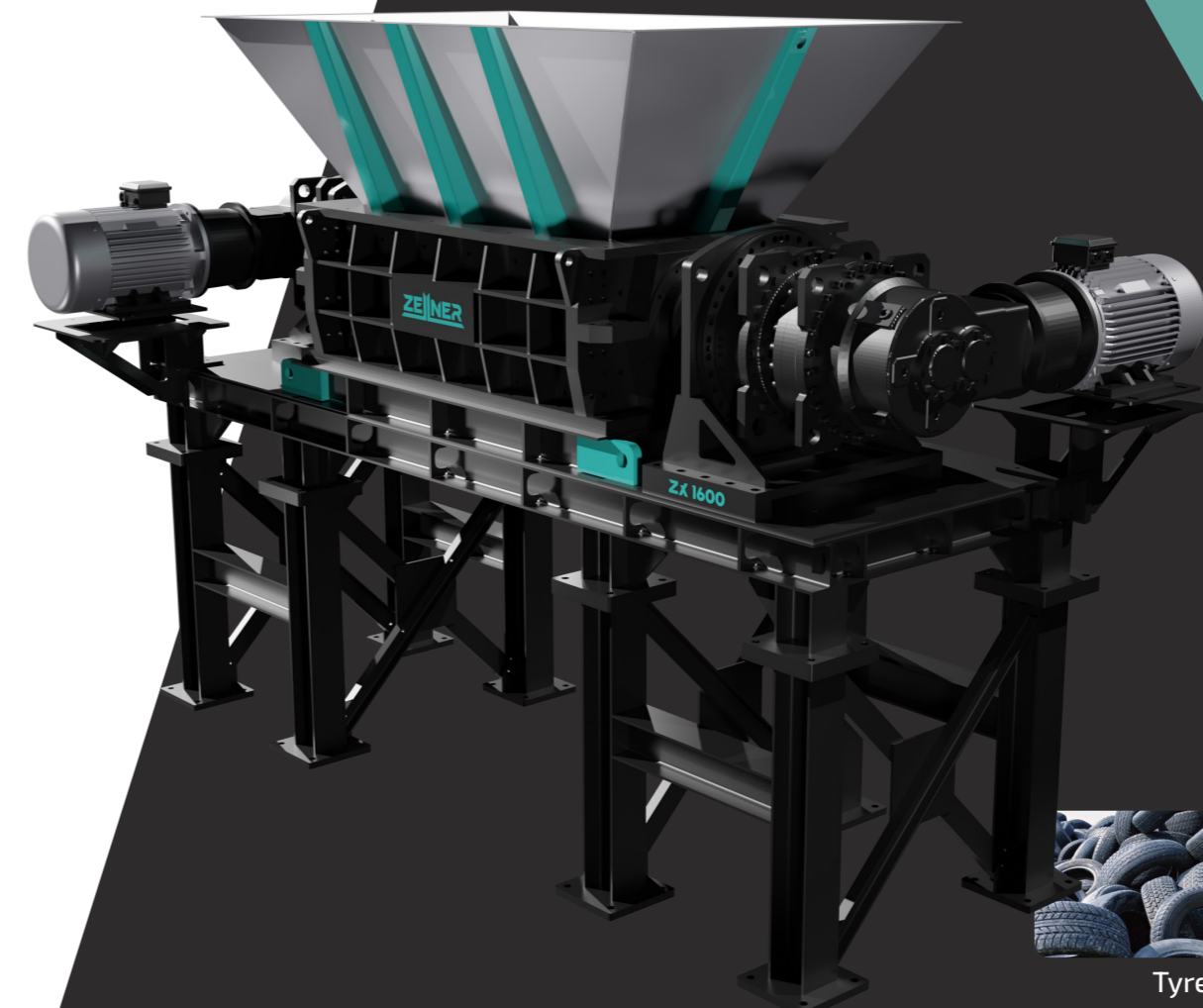

EN



# ZM Series ZX Series

Twin Shaft Shredder



Tyres

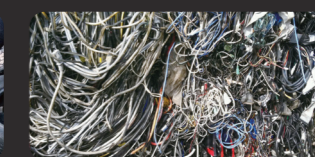

Cables



Car Shells



Electronic Appliances



Barrels



Wood

**Zellner Tech Systems**  
www.zellner.cz  
sales@zellner.cz

We reserve the right to make technical changes without prior announcement.  
All rights reserved.  
04/2026 Zellner Tech Systems

www.zellner.cz

## ZM Series Twin Shaft Shredder

Low speed, high torque operation minimises noise and power consumption, whilst achieving high throughput rates. These machines are particularly suited to the size reduction of bulky or voluminous materials which could include contamination such as metals or stones.



Model	ZM400	ZM800	ZM1000	ZM1200
Dimension (L x W x H) (mm)	1600 x 1225 x 1850	2710 x 1270 x 1850	3300 x 1900 x 2200	3580 x 1965 x 2200
Hopper Opening (L x H) (mm)	400 x 480	800 x 480	1050 x 750	1200 x 725
Discharge Height (mm)	600	640	850	875
Rotation Diameter (mm)	Ø 276	Ø 276	Ø 430	Ø 430
Rotation Speed (RPM)	13/7.7	14	14	15
Number of Blades (pcs)	10+10	20+20	25	15+15
Blade Width (mm)	20	20	40	40
Main Drive (kW)	7.5	7.5+7.5	18.5 + 18.5	22+22
Hopper Volume (L)	550	750	1130	1360
Weight (kg)	Approx 1470	Approx 2300	Approx 5200	Approx 5120



### Rotary Screen

To effectively control the output product size, a circular screen mounted around the cutting chamber is the ideal solution. The rotary screen runs at low speed, the oversized fractions are recirculated back to the cutting chamber for further shredding, whilst the sized fraction falls through the screen to the next process.



### Blade Hook Design

Blade hook designs can be selected according to the nature of the materials being processed. The length of the output material fractions can be controlled by the number of hooks. Experienced selection of the blade hook profile and quantity is of prime importance.

## ZX Series Twin Shaft Shredder

ZX Series Twin Shaft Shredders are extremely high torque, high throughput, rotating shear type size reduction machines often used for pre-shredding of large volume or high strength materials which may contain contamination. The unique modular split chamber design, provides excellent access to key components therefore reducing maintenance downtime and service costs.

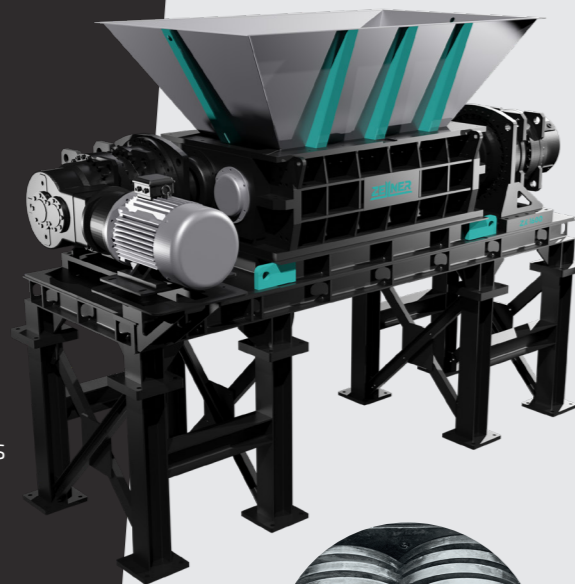

Model	ZX1500	ZX1600	ZX1800	ZX2000	ZX2200
Dimension (L x W x H) (mm)	6350 x 2600 x 4000	5150 x 2210 x 2600	7000 x 3050 x 4000	7000 x 3400 x 4000	7000 x 3700 x 4000
Hopper Opening (L x H) (mm)	1500 x 1440	1600 x 880	1800 x 1440	2000 x 1440	2200 x 1440
Discharge Height (mm)	1550	970	1550	1400	1400
Cutting Circle (mm)	Ø 750	Ø 515	Ø 750	Ø 750	Ø 750
Rotation Speed (RPM)	5.4-12	5.4-15	5.4-12	5.5-10	5.5-10
Number of Blades (pcs)	30 (50mm)/20 (75mm)	32	24 (75mm)/18 (100mm)	26 (75mm)/20 (100mm)	29 (75mm)/22 (100mm)
Blade Width (mm)	50/75	50	75/100	75/100	75/100
Main Drive (kW)	55+55	45+45	75+75	110+110	132+132
Hopper Volume (L)	3600	2000	4000	4200	4400
Weight (kg)	Approx 27700	Approx 11400	Approx 32450	Approx 43750	Approx 53500



### Blade Configuration & Width

Blade profile and width can be specified to suit the type of materials being processed. The width of the output material fractions can be controlled by the thickness of blades. Careful selection of the blade configuration and width is recommended to ensure optimum shredder performance.



### Hydraulic Force Feeder

A hydraulic force feeder is available to actively press the input material down into the cutting zone between the two shearing shafts. This holding action prevents material from riding over the blade hooks, thus greatly improving the cutting efficiency and throughput of the machine. The thoughtful, modular design of the feeder and associated hydraulic power unit provides unhindered access during maintenance, simplifying routine hydraulic oil changes and other maintenance tasks.



### Segmented Blades

The segmented blade design can greatly reduce the blade changing time and cost. The blade comprises of the blade holder, and two types of blade segments, with and without hooks. Worn blade segments can quickly and easily be removed and replaced by simply removing the securing screws. No need to remove blade holders from the shafts results in simplified maintenance and reduced downtime. Various blade configurations, hook profiles and widths available.

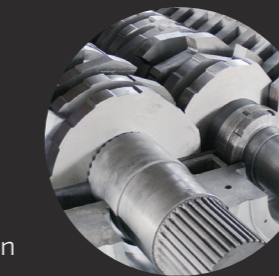

### Splined Drive Shafts

Hexagonal shafts are still considered by many to be an effective design, and if it wasn't for the wear and maintenance problems caused by loose blades rocking on the shafts, particularly in demanding applications with frequent reversals, they would still be preferred by many users. We have resolved these issues caused by loose blades with our splined shaft design, which securely locks blades and spacers on the drive shafts, eliminating blade rocking and prolonging shaft life.