

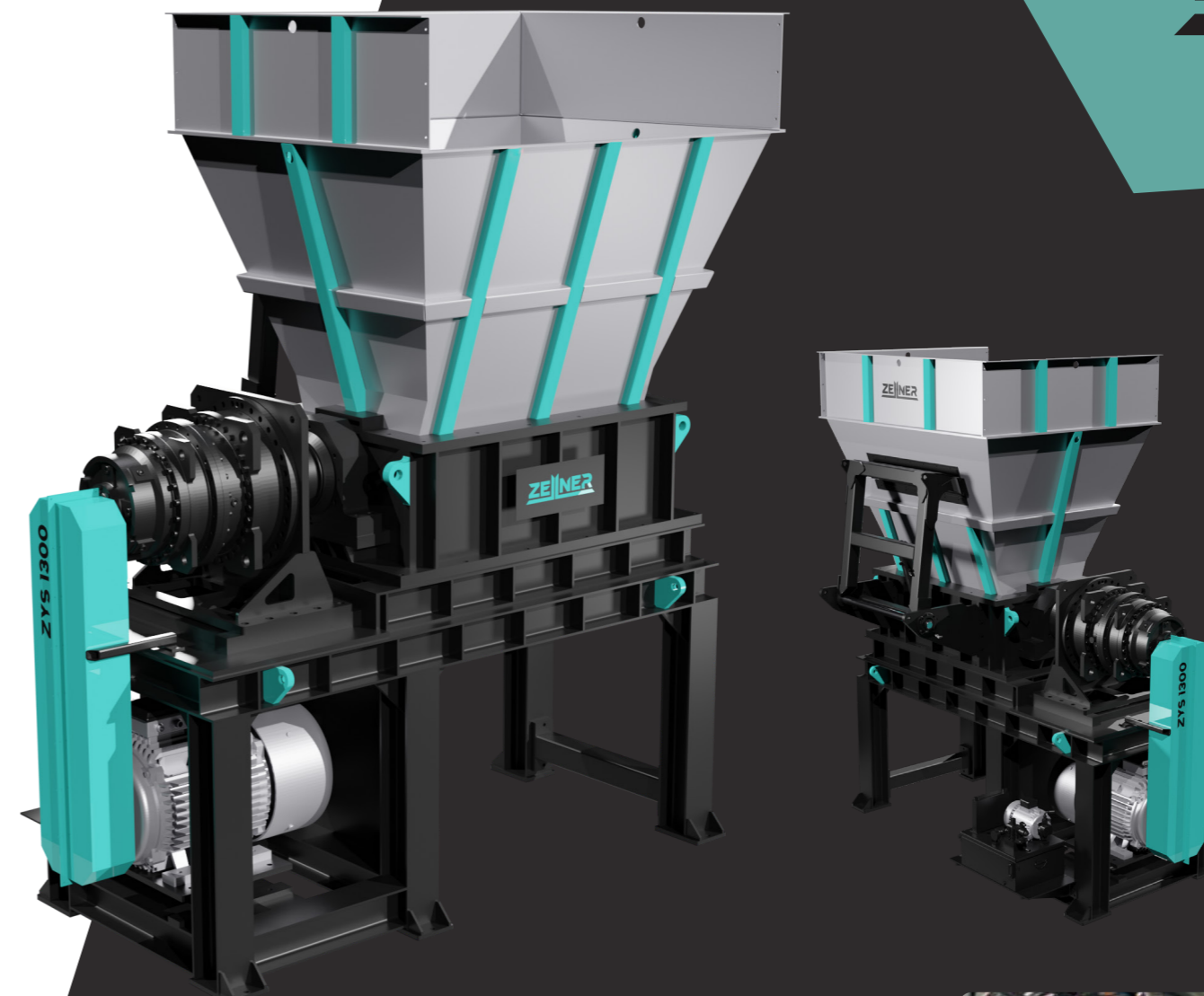

EN



ZYS Series

Pre-Shredder

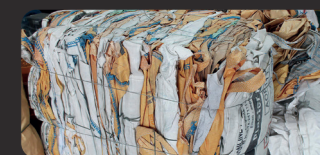

PP big bags



PP/PVC labels

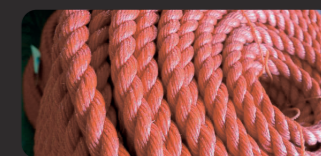

PP/Nylon ropes

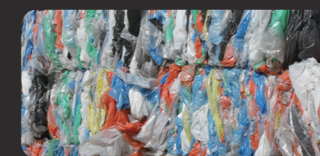

PP plastic film

Zellner Tech Systems
www.zellner.cz
sales@zellner.cz

We reserve the right to make technical changes without prior announcement.
All rights reserved.
04/2026 Zellner Tech Systems

www.zellner.cz

ZYS Series

Pre-Shredder

ZYS series pre-shredders are designed for processing high strength and tough materials with high levels of contamination. The machine pre-shreds compressed and baled material into fractions for further processing. Film type materials are opened up to enable effective cleaning and washing.

ZYS shredders are usually positioned at the beginning of a film washing system, though the machines can operate as stand-alone units for in-house recycling as well.

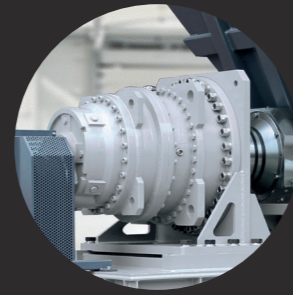

Heavy Duty Gearbox

- Equipped with planetary gearbox, low speed, high torque
- Providing high tearing and shredding force
- Simply maintained drive assembly, extremely robust in operation



Hydraulic Force Feeder

- Force feeding material to cutting chamber for material shredding
- Modular design hydraulic pack, providing unhindered access during maintenance and simplifying routine

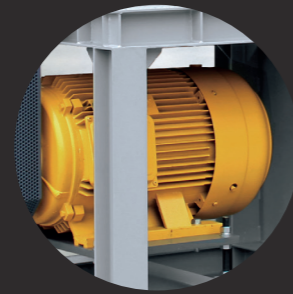

Drive & Control

- Equipped with powerful electric drive motor
- Bi-directional motor running for automatic rotor forward and reserve rotation
- Optional VFD control

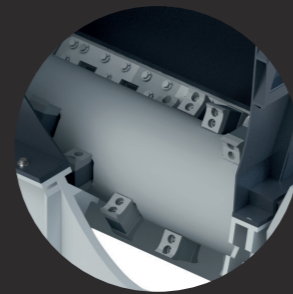

Rotor & Blade Design

- Durable shredding blades manufactured from high quality steels, suitable for shredding tough materials.
- Wear resistant rotor with tungsten surface coating for abrasive applications

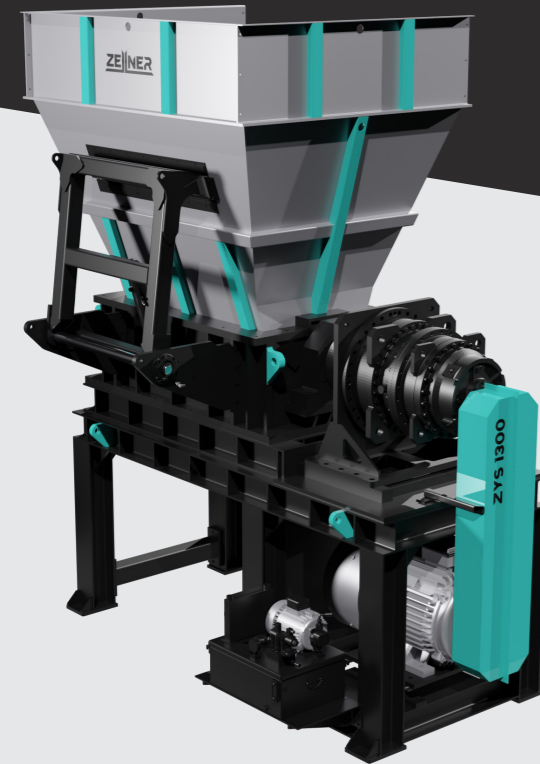

Model	ZYS1000	ZYS1300	ZYS1500
Dimension (L x W x H) (mm)	2900 x 1290 x 3800	3200 x 1290 x 3800	3400 x 1290 x 4000
Hopper Opening (L x H) (mm)	1780 x 1680	2080 x 1680	2280 x 1680
Rotation Diameter (mm)	Ø 600	Ø 600	Ø 600
Operation Length (mm)	1000	1300	1500
Rotation Speed (RPM)	10	10	10
Number of Rotor Knives (pcs)	24	32	40
Number of Counter Knives (pcs)	14	18	22
Main Drive (kW)	45	75	90
Weight (kg)	Approx 7700	Approx 8050	Approx 9300